

REVISIONS

LTR	DESCRIPTION	DATE	APPD
A	FM APPR. ADDED, "L" TOLERANCES ADDED	2-5-79	CN143
B	FM REMOVED	12-18-91	CN1577

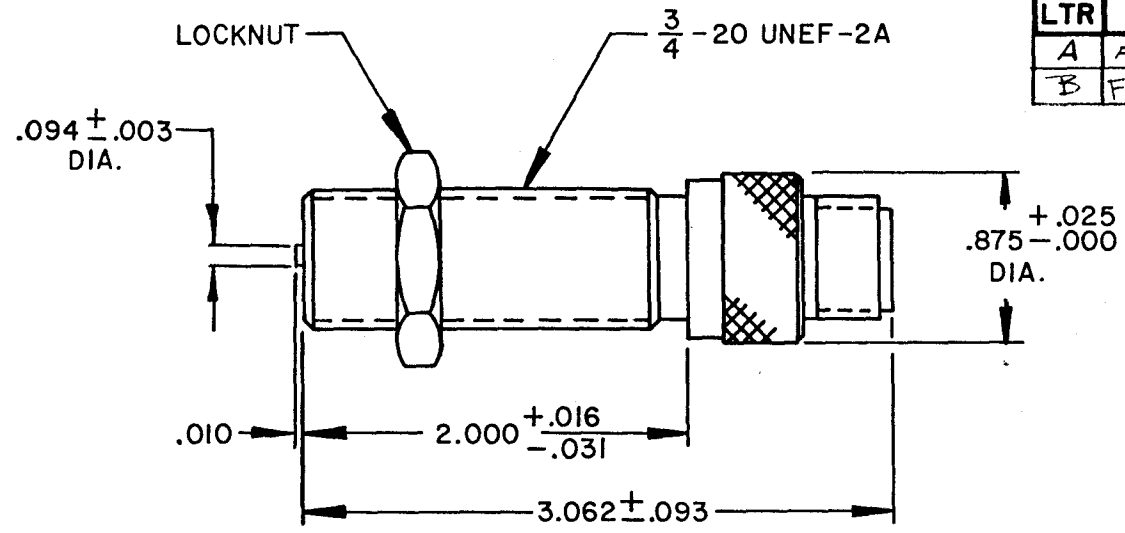

TEMPERATURE RANGE	OUTPUT VOLTAGE PEAK TO PEAK	DC RESISTANCE OHMS	INDUCTANCE MILLIHENRYS	OUTPUT CONNECTOR	INSULATION RESISTANCE	NET WEIGHT
-65°F TO +225°F	13-17 VOLTS (SEE NOTE 1) 7V TYP. AT 50 IPS	230-280 AT 75°F	19-25 AT 1KHz.	MATES WITH MS3106A-10SL-4S (SEE NOTE 2)	100 MEGOHMS MIN. AT 500VDC, COIL TO HOUSING	3.5 OZ. AVG.

NOTES:

- TESTED AT 1000 INCHES/SECOND WITH A 16 PITCH, 40 TOOTH GEAR, 0.005" CLEARANCE AND 100K OHM LOAD SHUNTED BY 250 MMF.
- WITH APPROACH OF FERROUS METAL, PIN "B" IS POSITIVE WITH RESPECT TO PIN "A".

LIMITED OUTPUT CURRENT AND VOLTAGE

CONSTRUCTION:
 HOUSING - 303 STAINLESS STEEL
 POLE PIECE - 416 STAINLESS STEEL
 POTTING - EPOXY RESIN

UNLESS OTHERWISE SPECIFIED DIMENSIONS ARE IN INCHES TOLERANCES ARE		
FRACT.	DEC.	ANGLES
± 1/64	.XXX ± .005 .XX ± .01	± 1/2°
MATERIAL:		
FINISH:		

DYNALCO® CORPORATION
 FORT LAUDERDALE, FLORIDA

DRAWN	Ralph D.	DATE	4-10-78
APPROVED	<i>[Signature]</i>		4/10/78

TITLE
MAGNETIC PICKUP MODEL M139

SCALE	SIZE	DRAWING NUMBER	REV.
—	A	8000139	B

DO NOT SCALE THIS DRAWING